



DUPLEX PRESSURE PUMP CONTROLLER **D-PPC**

An Innovative Duplex Pressure Pump Controller Designed for: Residential, Commercial, Municipal, and Water Pressure System Applications.

Water Pressure Switch Operation

FEATURES:

- Modular circuit board
- Minimum RUN timer
- Automatic alternations
- Hand-off auto switch
- LED test / alarm silence / systems test push button
- Programmable switch, lead/lag or alternate
- Motor RUN indicators
- Power ON indicator
- Pressure ON indicators
- Low suction pressure alarm (audible and visual)
- Motor contactors and circuit protectors
- Remote alarm (12VDC output)
- Easy troubleshooting and maintenance
- UL & CSA approved

- 120 OR 240 VOLT - SINGLE PHASE FROM 0.3 TO 1.5 HP
- 208, 480 OR 575 VOLT - 3 PHASE FROM 0.5 TO 50 HP

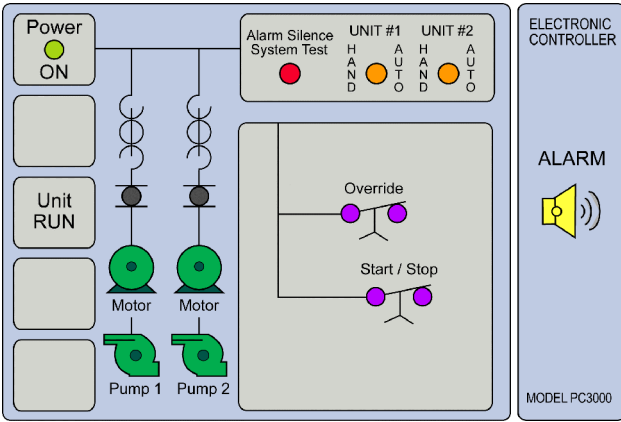

Northwest Tech-Con System's D-PPC high quality duplex pressure control panel is built to maintain water pressure in various systems. Specifically designed by NWTC, they are part of a booster control panel series, for use with a complete line of pressure pumps to provide maximum protection efficiency for all models. A low voltage control module is used to operate the starting, stopping, and alternation of the pumps, with one pump operating to handle normal pressure. A second pump becomes operational when system pressure is too low. A built-in alarm system in the control module also operates when the suction pressure is low. In the case of a duty pump being switched off under overload, high temperature, seal leakage, etc., the controller will automatically start the lag pump.

Ordering Information

D-PPC — 120 — A B E

 | | |

Duplex Voltage Options

Pressure Pump by

Controller Letter