



# SIMPLEX PUMP CONTROLLER

# SCP

**An innovative Simplex Pump Controller designed for:  
 Residential, Commercial, Municipal, Sump and Sewage Applications**

120 OR 240 VOLT - SINGLE PHASE FROM 0.3 TO 1.5 HP

208, 480 OR 575 VOLT - 3 PHASE FROM 0.5 TO 100 HP

## 3 Float Switch Operation

### FEATURES:

- Modular Circuit Board PC 3000 / S
- Low Energy Output to Floats
- Hand-off Auto Switches
- LED Test / Alarm Silence / Systems Test Push Button
- Motor RUN Indicator
- Power ON Indicator
- LED Float Level Indicators
- High Level Alarm (audible and visual)
- High Peak Sonalert Alarm
- Remote Alarm (12VDC output)
- Motor Contactor and Circuit Protector
- UL & CSA approved



**Northwest Tech-Con System's** SCP panel is a high quality Simplex Control System made for automatic operations. It is specifically designed by **NWTC** to provide maximum protection and efficiency with a complete line of pumps. A low voltage control module is used to operate the starting and stopping of the pumps, with one pump operating to handle normal flow. A built-in alarm system in the control module will sound if the water reaches a high level.

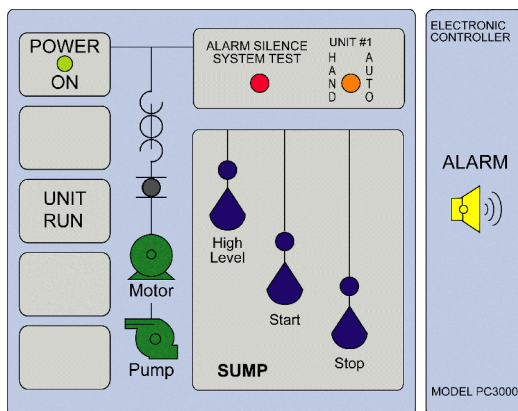

### Ordering Information

SCP — 120 — A B E  
 | | |  
 Simplex Voltage Options  
 System by  
 Letter